



TECHNICAL MANUAL

Frequency converters

VECTOR-100 EKF

1 DESCRIPTION

Frequency converter VECTOR-100 EKF is designed to control the rotation speed of industrial electric motors. Frequency converter enables accurate control of the motor rotation speed based on external input. Frequency converter complies with IEC 61800-5-1, IEC 61800-3 requirements.

Type code:

VT100-XX-XX

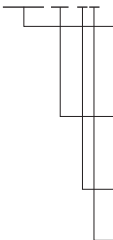

Frequency converters VECTOR series
VT100 – industrial frequency converter
VECTOR-100 EKF.

Rated (extended) motor power: 0R4 – 0,4 (0,75) kW;
0R75 – 0,75 (1,5) kW; 1R5 – 1,5 (2,2) kW; 2R2 – 2,2 (4) kW,
4 – 4 (5,5) kW, 5R5 – 5,5 (7,5) kW; 7R5 – 7,5 (11) kW;
11 – 11 (15) kW ... 560 – 560 (630) kW; 630 – 630 (750) kW.

Input phases:

1 – single-phase 230V;
3 – three-phases 3x400V.

Braking unit:

B – integrated;
No marking – not included.

2 TECHNICAL DATA

Main technical data are given in Table 1 below.

Table 1

Characteristics	Значения
Minimal single-phase power (1x230V), kW	0,4
Maximum single-phase power (1x230V), kW	2,2
Minimal three-phase power (3x400V), kW	0,75
Maximum three-phase power (3x400V), kW	630
Output frequency, Hz	0-600
Output voltage @ 3x400V input, V	400
Carrier frequency, kHz	0,4-16
Starting torque, %	SVC - 150 at 0,5 Hz V/F - 150 at 1 Hz
Overload capacity, %	150 for 60 s 180 for 3 s
Non-feedback vector control (SVC)	Available
Scalar control V/F	Available
Inputs/Outputs	
Digital input connections	5 to 7
Analog input connections	2 to 3
Digital output connections, relay/transistor 0,4 to 7,5 kW > 11 kW	1/2 2/2
Analog output connections	2
Interfaces	
RS-485, Modbus RTU protocol	Available
Functions	
PID	Available
Sequential PLC	Available
Design	
Cooling	Fan
Ambient temperature, °C	-10...+50
Degree of protection	IP20

Please see Table 2 below for available frequency converter configurations.

Table 2

Item code	Name
VT100-0R4-1B	Frequency converter VECTOR-100 0,4/0,75kW 1x230V EKF
VT100-0R7-1B	Frequency converter VECTOR-100 0,75/1,5kW 1x230V EKF
VT100-1R5-1B	Frequency converter VECTOR-100 1,5/2,2kW 1x230V EKF
VT100-2R2-1B	Frequency converter VECTOR-100 2,2/4kW 1x230V EKF
VT100-0R7-3B	Frequency converter VECTOR-100 0,75/1,5kW 3x400V EKF
VT100-1R5-3B	Frequency converter VECTOR-100 1,5/2,2kW 3x400V EKF
VT100-2R2-3B	Frequency converter VECTOR-100 2,2/4kW 3x400V EKF
VT100-4R0-3B	Frequency converter VECTOR-100 4/5,5kW 3x400V EKF
VT100-5R5-3B	Frequency converter VECTOR-100 5,5/7,5kW 3x400V EKF
VT100-7R5-3B	Frequency converter VECTOR-100 7,5/11kW 3x400V EKF
VT100-011-3B	Frequency converter VECTOR-100 11/15kW 3x400V EKF
VT100-015-3B	Frequency converter VECTOR-100 15/18kW 3x400V EKF
VT100-018-3B	Frequency converter VECTOR-100 18/22kW 3x400V EKF
VT100-022-3B	Frequency converter VECTOR-100 22/30kW 3x400V EKF
VT100-030-3B	Frequency converter VECTOR-100 30/37kW 3x400V EKF
VT100-037-3B	Frequency converter VECTOR-100 37/45kW 3x400V EKF
VT100-045-3	Frequency converter VECTOR-100 45/55kW 3x400V EKF
VT100-055-3	Frequency converter VECTOR-100 55/75kW 3x400V EKF
VT100-075-3	Frequency converter VECTOR-100 75/90kW 3x400V EKF
VT100-090-3	Frequency converter VECTOR-100 90/110kW 3x400V EKF
VT100-110-3	Frequency converter VECTOR-100 110/132kW 3x400V EKF
VT100-132-3	Frequency converter VECTOR-100 132/160kW 3x400V EKF
VT100-160-3	Frequency converter VECTOR-100 160/185kW 3x400V EKF
VT100-185-3	Frequency converter VECTOR-100 185/200kW 3x400V EKF
VT100-200-3	Frequency converter VECTOR-100 200/220kW 3x400V EKF
VT100-220-3	Frequency converter VECTOR-100 220/250kW 3x400V EKF
VT100-250-3	Frequency converter VECTOR-100 250/280kW 3x400V EKF
VT100-280-3	Frequency converter VECTOR-100 280/315kW 3x400V EKF
VT100-315-3	Frequency converter VECTOR-100 315/350kW 3x400V EKF
VT100-355-3	Frequency converter VECTOR-100 350/400kW 3x400V EKF
VT100-400-3	Frequency converter VECTOR-100 400/450kW 3x400V EKF
VT100-450-3	Frequency converter VECTOR-100 450/500kW 3x400V EKF
VT100-500-3	Frequency converter VECTOR-100 500/560kW 3x400V EKF
VT100-560-3	Frequency converter VECTOR-100 560/630kW 3x400V EKF
VT100-630-3	Frequency converter VECTOR-100 630/750kW 3x400V EKF

3 OVERALL AND INSTALLATION DIMENSIONS

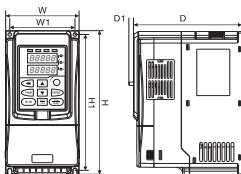

Fig. 1 Overall dimensions for VECTOR-100 frequency converters 0,4 to 7,5 kW

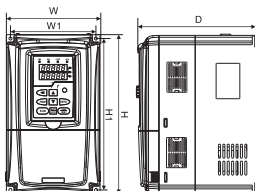

Fig. 2 Overall dimensions for VECTOR-100 frequency converters 7,5 to 22 kW

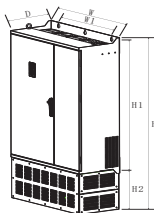

Fig. 3 Overall dimensions for VECTOR-100 frequency converters >30 kW

Table 3

Name	W	W1	H	H1	D	Mounting hole diameter, mm
VT100-0R4-1B	90	80	187	177	133	5,7
VT100-0R7-1B	90	80	187	177	133	5,7
VT100-1R5-1B	90	80	187	177	133	5,7
VT100-2R2-1B	90	80	187	177	133	5,7
VT100-0R7-3B	90	80	187	177	133	5,7
VT100-1R5-3B	90	80	187	177	133	5,7
VT100-2R2-3B	90	80	187	177	133	5,7
VT100-4R0-3B	100	90	207	197	142	5,7
VT100-5R5-3B	130	115	247	236,5	162	5,7
VT100-7R5-3B	130	115	247	236,5	162	5,7
VT100-011-3B	160	146	272	259	201	9
VT100-015-3B	160	146	272	259	201	9
VT100-018-3B	211	196	313	299	202	9
VT100-022-3B	211	196	313	299	202	9
VT100-030-3B	252	201	418	399	206,9	9
VT100-037-3B	252	201	418	399	206,9	9
VT100-045-3	299	240	603	581	276,7	10
VT100-055-3	299	240	603	581	276,7	10
VT100-075-3	338	280	643	619	312	12
VT100-090-3	338	280	643	619	312	12
VT100-110-3	338	280	643	619	312	12
VT100-132-3	410	320	803,0	776	383,7	12
VT100-160-3	410	320	803,0	776	383,7	12
VT100-185-3	410	320	803,0	776	383,7	12
VT100-200-3	410	320	803	776	383,7	12
VT100-220-3	650	520	1078,8	1046,8	430,2	12
VT100-250-3	650	520	1078,8	1046,8	430,2	12
VT100-280-3	650	520	1078,8	1046,8	430,2	12
VT100-315-3	650	520	1078,8	1046,8	430,2	16
VT100-355-3	800	700	1320	1280	438	16
VT100-400-3	800	700	1320	1280	438	16
VT100-450-3	800	700	1320	1280	438	16
VT100-500-3	1028	800	1500	1460	450	16
VT100-560-3	1028	800	1500	1460	450	16
VT100-630-3	1028	800	1500	1460	450	16

4 INSTALLATION AND OPERATION

For frequency converter installation requirements please, refer to Fig.4 and Fig.5, as well as Table 4 below.

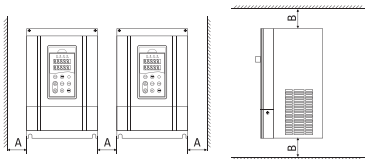

Fig.4 Installation of multiple frequency converters in a row

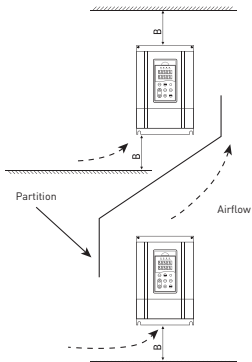

Fig.5 Vertical installation of multiple frequency converters

Table 4

Converter capacity, kW	Value, mm	
	A	B
0.4-15	≥50	≥100
18,5-45	≥50	≥200
Over 55	≥150	≥300

Connect communication lines as shown on the wiring diagrams (Fig.6 and Fig.7 below).

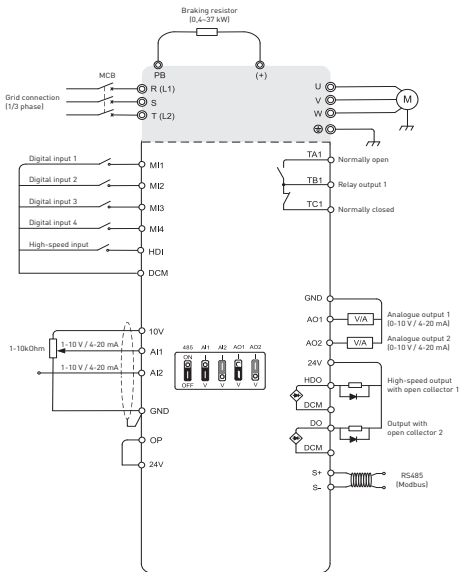

Figure 6. Wiring diagram for frequency converters VECTOR-100 0,4 to 7,5 kW

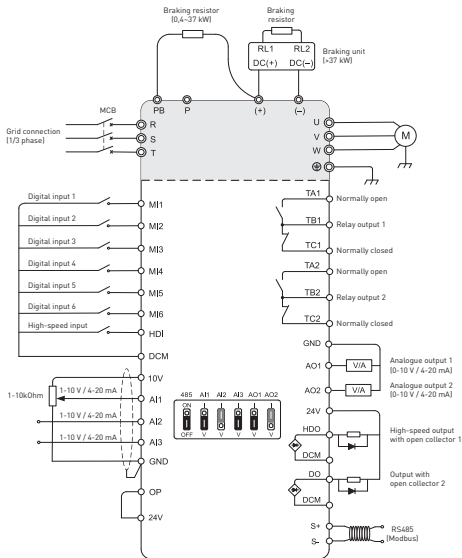

Figure 7. Wiring diagram for frequency converters VECTOR-100 over 7,5 kW

COMMISSIONING AND START-UP OF FREQUENCY CONVERTER VECTOR-100 EKF

Cold loop test

Before powering up the frequency converter for the first time please ensure the following:

- all power circuits are connected to the frequency converter as per technical and operation manual, all power cables are correctly connected and properly secured to their terminals;
- all auxiliary equipment is connected to the frequency converter as per technical and operation manuals for the frequency converter and respective auxiliary equipment;
- all communication circuits are connected to the frequency converter as per technical and operation manual;
- there are no short faults in the input/output communication and power circuits, connected to the frequency converter;
- frequency converter is properly grounded.

Commissioning and initial set-up

Initial power-up of the frequency converter should be performed with the motor disconnected (disconnected output power cables). After energizing the input power circuit and powering up the frequency converter, please make sure there are no faults and that the frequency converter is in the «STOP» mode. In the event of faults, please refer to the technical and operation manual.

WARNING!

If the frequency converter has been out of operation for an extended time (over 6 months), or if there has been a delay of more than 6 months between the converter delivery and initial power-up, please power up the converter with output power cables disconnected and keep it energized for one hour. The frequency converter should remain in the «STOP» mode for the duration of this period. This is required to properly reform the DC capacitors of the frequency converter.

5 DELIVERY SCOPE

1. Frequency converter – 1 pc.;
2. Operation manual - 1 pc.;
3. Technical manual – 1 pc.;
4. External operator panel ribbon cable - 1 pc.;
5. External operator panel mounting frame - 1pc.

6 SAFETY REQUIREMENTS



WARNING!

If the equipment is connected to the grid, there will be hazardous voltage inside the frequency converter.

Improper installation of the electric motor or the frequency converter may cause damage to the equipment, injury or death. Please, follow all the instructions in this manual and maintain compliance with national and local safety rules and regulations.

Frequency converters shall be operated and serviced only by qualified personnel.

Make sure enough time has passed after de-energizing the circuit before connecting/disconnecting the electric motor.



WARNING!

Do not disengage the connection between electric motor and the grid while the frequency converter is connected to the grid.

Do not operate frequency converters with visible physical damage.

7 TRANSPORTATION AND STORAGE

Frequency converters can be transported by any means of enclosed transport that protects the packed goods from mechanical impact and weather exposure.

Frequency converters shall be stored indoors in their original packaging at the ambient temperatures from -25°C to +50°C and relative humidity of max. 98% at +25°C.

8 MANUFACTURER'S WARRANTY

The manufacturer guarantees the compliance of frequency converters with the applicable standards, regulations and specifications, subject to following any and all operation, transportation and storage requirements. Warranty period: 3 years from the date of sale.

Shelf life: 3 years from the date of manufacture specified on the product package or housing.

Service life: 7 years

Manufacturer: for information, refer to the product package.

Importer and EKF trademark service representative: EKF ELECTRICAL SOLUTION – FZCO, Dubai Silicon Oasis, DDP, Building A2, Dubai, United Arab Emirates.

Importer and EKF trademark service representative on the territory of the Russian Federation: OOO «Electroresheniya», Otradnaya st., 2b bld. 9, 5th floor, 127273, Moscow, Russia. Tel.: +7 [495] 788-88-15.

Importer and EKF trademark service representative on the territory of the Republic of Kazakhstan: TOO «Energoresheniya Kazakhstan», Kazakhstan, Almaty, Bostandyk district, Turgut Ozal st., 247, apt 4.

9 CERTIFICATE OF ACCEPTANCE

Frequency converters VECTOR-100 EKF have been approved for operation.

Date of manufacture:

For information, refer to the product package.

Quality control stamp



www.ekfgroup.com